

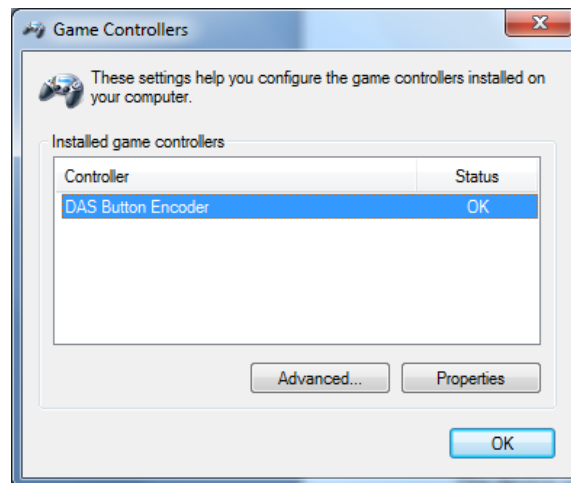

[Iflysim's.com](http://Iflysim's.com)

The USB Button Encoder Interface Board uses standard HID drivers so no driver install is required, simply plug the Board into the standard USB connection on either your PC or Mac and the computer will automatically detect and install the device.

The device will be recognized as a Game Controller "DAS Button Encoder"



### Installing Buttons

Once successfully installed the Button Encoder with any momentary type button and 32 can be connected. Multiple Boards can be connected to provide additional sets of 32 buttons. The Board will detect the press of a button when the button is grounded.

To install buttons simply use any of the available 32 I/O pins and connect one pole of the button to the appropriate I/O pin and the other pole to ground. Each Button is connected directly to an I/O pin on the microcontroller allowing for fast response and allows for simultaneous button pressing (i.e. there are no button arrays used in this board)

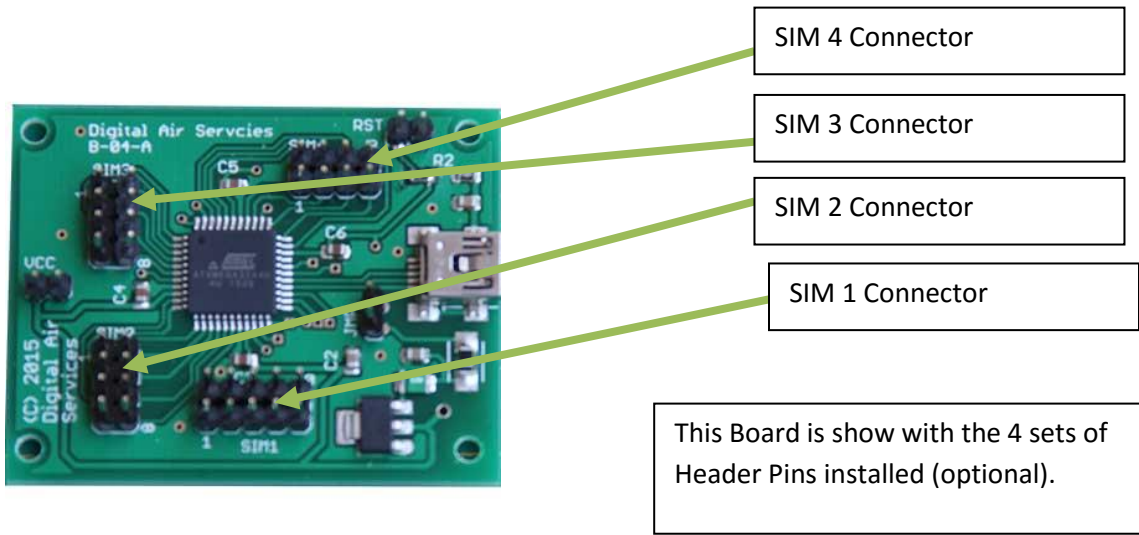

Button Assignments (Windows)

8	9	10	11	12
28	27	14	13	GND

SIM 1 (View from Top)

3	4
2	5
1	6
26	7

SIM 2

17	18
16	23
15	24
22	25

SIM 3

19	20	21	29
32	31	PDI	30

SIM 4 (View from Top)

Note PIN#5 is for PDI Programming and should not be connected to any button.

There are 3 ground pins on the board, any of which can be used for button grounding which will require user supplied wiring and connectors.

The Header pins labeled VCC

VCC (3.3 Volts)	Ground
--------------------	--------

VCC

RST	Ground
-----	--------

RST

The Reset headers allow for an external reset button to be connected, connect the reset button between RST and GND. The RST line is pulled high by a 10K resistor.

### **Technical Details**

This section provides additional details which are generally not required for normal usage.

The controller uses a XMEGA32 microcontroller which is supplied its voltage from the USB Bus voltage and is regulated down to 3.3Volts via an LDO Regulator. The circuit is protected via a protection diode and a Fuse rated to 500mA. The circuit is not designed to provide power to other devices as this may cause excessive current drain.

The circuit is capable of being powered by external power by removing the JMP connector and powering the circuit with an external power supply rather than that supplied from the USB Bus. The LDO is rated to 1A.

For further details and questions please visit <http://iflysim.com> or email [info@iflysim.com](mailto:info@iflysim.com)